



Operator and Installation Manual

Cummins **Onan**

Performance you rely on.™



Energy Command 20

Operation and Installation Manual

PN 018-01043 Rev 1.7b

Energy Command 20

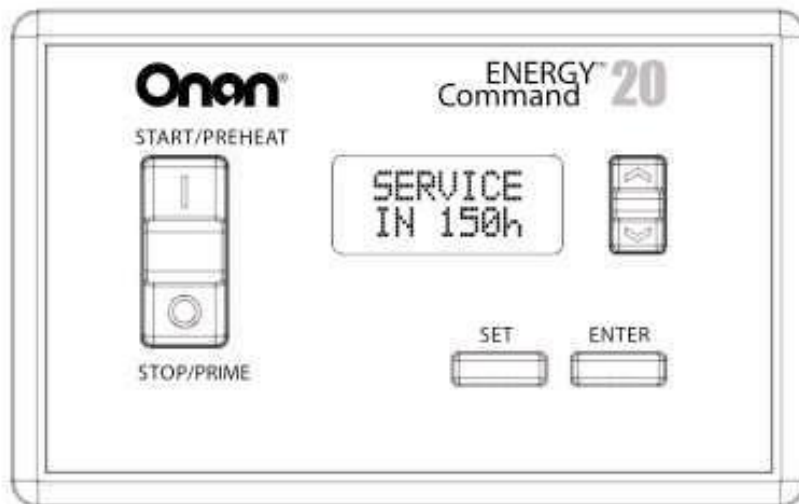

General

The Energy Command 20 (EC-20) is a Generator Controller that allows manual starting and stopping of Onan Diesel, Gasoline, and Liquid Propane (LP) engine driven AC generators (referred to in this manual as a genset). EC-20 provides system information such as the battery state-of-charge as well as key operational information such as genset service and fault messages.

This system is only for use with Onan Recreational Vehicle genset (Quiet Diesel gensets, and Gasoline/LP gensets).

For personal safety and to avoid equipment damage;

- Thoroughly read and understand this Operation and Installation Manual before using or installing.
- The EC-20 should be installed by qualified persons following wiring and installation details provided in this Operation and Installation Manual
- If these instructions conflict with the genset manuals, the genset manuals should take precedence.
- Keep these instructions with the genset manuals.

Safety Precautions

Exposure to carbon monoxide, moving parts, and electricity hazards is possible.

!!WARNING!!

CARBON MONOXIDE is deadly! MOVING PARTS and ELECTRICITY can cause severe personal injury or death. To reduce exposure to these hazards, do not operate the genset when:

- ***Sleeping in vehicle, unless vehicle has a working CARBON MONOXIDE detector***
- ***When vehicle is parked in garage or confined space***
- ***Servicing batteries***
- ***Servicing electrical appliances***
- ***Fueling vehicle.***

Before storing or servicing, disable genset by disconnecting battery or genset remote harness.

OPERATION PANEL QUICK REFERENCE

START/STOP: Works exactly like the genset switch. If the genset switch has a run light and flashes diagnostics, the EC-20 run light will also be on when the genset is running, flash during preheat, and flash genset fault messages.

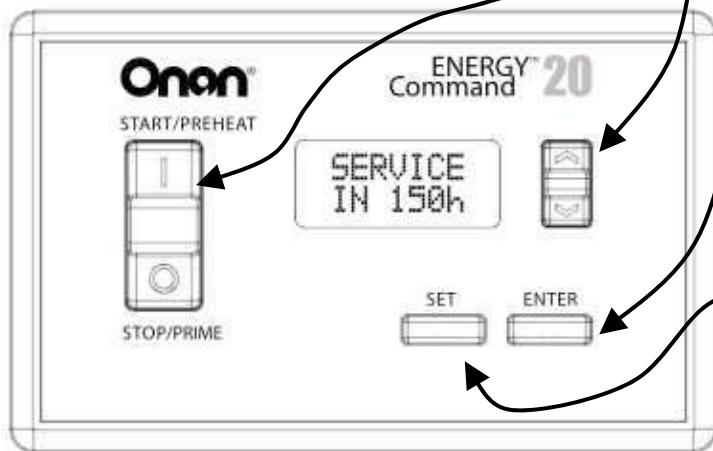

UP/DOWN: This key is used to scroll through display choices and change values that can be SET.

ENTER: This key is used to store values that have been changed, and to respond to display commands.

SET: This key is used to display and change settable values.



Operation of the Energy Command 20

Overview

This section describes how to use the Energy Command 20 (EC-20). The Quick Reference page defines key locations and Figures 1, and 2 are the display screen flow charts.

Manual Genset Operation

STOP/START Switch

The Energy Command 20 (EC-20) START/STOP switch is used to manually start and stop the genset. This switch functions exactly like the stop/start switch located on the genset.

The EC-20 START/STOP switch has a red backlight to indicate the genset is running. If the genset is equipped with diagnostics the EC-20 will also flash fault messages. It will also decode the flashing fault message and display a text fault message.

The genset may be started using the START/STOP switch even if there is no power to the EC-20. Once the genset is running the EC-20 display will turn on.

Default Display

The House Battery Voltage and the charge level indicator are displayed on power up. After 10 minutes with no key presses the backlight is turned off to save power. Touch any key to turn the backlight on.

Using the Keys

UP/DOWN Key

UP/DOWN key is used to navigate through the display menu and to change values or parameters that can be set by the user. If the UP/DOWN key is held the display will scroll through the menu.

SET Key

SET is used to start the process of changing values that can be set by the user.

ENTER Key

ENTER is used to store a value that has been changed. It is also used to ENTER the SETUP & INFO DISPLAYS. The ENTER key may also be required to exit a screen or to acknowledge an action.

Using the Displays

See Figure #1 Main Display Map.

House Battery Charge Level Indicator

The house battery charge level indicator uses both short and long term voltage trends to determine the battery level. It is intended as a guide to the state-of-charge (SOC) of the battery and its ability to sustain the load.

House Battery Voltage

The house battery voltage can be used to assess the performance of the charging system and to estimate the battery SOC. To estimate battery SOC, no loads should be on and the battery should not be charging. Ideally, the battery will have "rested" in this state for 24 hours. Letting the battery rest for 30 minutes will give an idea but the SOC estimate will be less accurate.

Open Circuit Voltage vs. State-of-Charge 12 Volt Batteries of Various Types

State of Charge	Battery Electrolyte Type		
	Liquid	AGM	Gelled
100%	12.6	12.9	12.8
75%	12.4	12.7	12.6
50%	12.2	12.4	12.3
25%	12.0	12.0	12.0
0%	11.8	11.8	11.8

Engine (Chassis) Battery

If a separate engine battery is wired to the EC-20 it is shown in the ENGINE Bat V display. There is no display if this feature is not wired. This is an optional feature.

SERVICE IN Display

The SERVICE IN display is a countdown service hour meter that indicates the genset next required service interval. To determine specific service items see the genset manual. When the service interval has elapsed the display alternates as shown below.



Display Alternates
Press ENTER to Reset
Service Hour-Meter

The SERVICE DUE message is displayed as soon as the service interval has elapsed. The UP/DOWN key still allows navigation through the main displays and all functions still work. After the genset is serviced navigate to the SERVICE DUE message and ENTER to reset the service interval hour-meter.

If the genset is serviced prior to the next service reminder, go to the SERVICE IN display and press SET, press ENTER to reset the service interval hour-meter.

The SERVICE IN display is also used to display genset faults and errors that may occur. If a fault or error has occurred, it will be displayed even if it no longer exists. When any key is pressed the message will be cleared.

The last fault message may be displayed by pressing the STOP switch three times. See the genset operating manual for details on the error codes and messages.

Genset Hour-meter

The genset hour meter displays the total elapsed time the genset has run since the EC-20 was installed. If the EC-20 is installed on an existing generator, see the SETUP section of this manual to adjust the hour meter.



Setting Up and Testing the Energy Command 20

Overview

This section describes how to Setup and Test the EC-20. Before using the EC-20 for the first time check to be sure that the unit is setup appropriately for the system. Also see Figures #1-4.

Setting GEN TYPE Is Required

The very first time the EC-20 is turned on (power applied) an initial setup procedure begins. The EC-20 requires setup of the GEN TYPE.

The genset type sets the Service Interval for service messages. The first service interval is 50 hours for all models. See SETUP GENSET to change the genset type after first power up.

Setting GEN TYPE

Genset type must be selected (SET) at first power up.



GEN TYPES TABLE 1

GEN TYPE	MODEL	Service In
QD 10/12	Quiet Diesel	250 hours
QD 6/8	Quiet Diesel	150 hours
QD 5.5	Quiet Diesel	150 hours
GAS/LP	Marquis, Microlite, Micro Quiet, CampPower	150 hours

The words SET NOW will be flashing. Use the UP/DOWN key and the table above to select the correct genset type. Press ENTER when the correct genset is displayed.

SETUP & INFO Displays

The SETUP & INFO displays are used to tailor the EC-20 to the installed genset. Refer to Figure #1 for the various main displays that are available. To access the SETUP & INFO displays use the UP/DOWN key to navigate to the SETUP & INFO display and press ENTER. (See Figure #2: Setup & Info Displays) The UP/DOWN key now allows scrolling through the various choices. To access a choice press the ENTER key. Again the UP/DOWN

key is used to navigate through the available displays. Use the ENTER To Exit display to continue through the previous displays or:

SYSTEM INFO Display

VERSION Display

The VERSION display shows the version control number for EC-20. Should it be necessary to contact customer service this number will help determine the specific configuration of your EC-20.

SETUP GENSET Displays

The SETUP GENSET displays are used to select the type of genset used with the EC-20 and to adjust the genset hour meter.

SETUP GENSET Display

To change the GEN TYPE after initially setting navigate to the SETUP & INFO display and press ENTER. Now navigate to the SETUP GENSET display and press ENTER. The GEN TYPE will be displayed. Press SET, the display will flash. Use the UP/DOWN key to select the GEN TYPE and press ENTER when the appropriate type is displayed. The GEN TYPE is stored in permanent memory and will not have to be changed unless the EC-20 is installed on a different type genset.

SET Gen Hour Display

If the EC-20 is installed on an existing genset check its hour-meter and record the reading. ENTER the SETUP & INFO menu and navigate to the SETUP GENSET display. Press ENTER and use the DOWN key to select the SET gen hours display. Press SET. The next display says, ENTER to unlock. This prevents unauthorized changes to the hour-meter. Press ENTER to continue.

The display will flash. Hold down the UP/DOWN key and scroll until the left most digit matches the desired value. Release the UP/DOWN key and wait four seconds for the underline to move to the next digit to the right and scroll to its desired value. Set each successive digit to the right until the correct genset hours are displayed press ENTER. The value is stored in permanent memory and will not have to be changed unless the EC-20 is installed on a different genset. The hour-meter in the EC-20 and the hour meter at the genset may differ slightly over time due to small differences in accuracy.

Installing the Energy Command 20

Overview

This section describes how to install the Energy Command 20 (EC-20).

General

This system is only for use with Onan Recreational Vehicle genset (Quiet Diesel gensets, and Gasoline/LP gensets).

The control circuitry is a 3-wire ground to start/stop type. Before installing, refer to the System Diagram, Figure 4, and select the appropriate wiring diagram, Figures 5 - 7, for connection to your genset. Consult an Onan distributor with any questions.

Appendix A shows the Onan gensets that are compatible with the EC-20 and the correct wiring figures and harnesses to use for each genset.

!CAUTION! For personal safety and prevention of equipment damage, only experienced personnel should install this system. The installer must wear safety glasses and protective clothing necessary for personal safety.

Installation Precautions

CAUTION! Always disconnect a battery charger from its AC source before disconnecting the battery cables. Otherwise, disconnecting the cables can result in voltage spikes high enough to damage the DC control circuits of the genset.

! WARNING! Unexpected starting of the genset set while working on it can cause severe personal injury or death. Prevent unexpected or accidental starting by disconnecting the genset battery cables {negative (-) first}, or by disconnecting the remote harness at the genset.

!WARNING! Arcing can ignite explosive hydrogen gas given off by batteries, causing severe personal injury. Arcing can occur if the negative (-) battery cable is connected and a tool being used to connect or disconnect the positive (+) battery cable accidentally touches the frame or other grounded metal part of the genset set or vehicle frame. To prevent arcing always remove the negative (-) cable first, and reconnect it last.

Specifications

Operating Temperature:	-20 to 70 degrees C (-4F to 158F)
Storage Temperature:	-40 to 70 degrees C (-40F to 158F)
Battery System:	12 Volt DC
Voltage Range:	8 – 35VDC
Typical Current Draw:	47mA @ 12V
L x W x D:	80.98 x 130.12 x 30.48 mm (3.188 x 5.125 x 1.20 inches)

INSTALLATION CODES AND STANDARDS FOR SAFETY

The vehicle builder or EC-20 installer bears sole responsibility for the appropriate selection of components, for proper installation and for obtaining approvals from any authorities having jurisdiction for the installation. EC-20 is suitable for installation in accordance with:

- ANSI A 1192 (NFPA No. 1192)-Standard on Recreational Vehicles
- NFPA No.70, Article 551-Recreational Vehicles and RV Parks
- CAN/CSA-Z240.6.2 Recreational Vehicles

Federal, State and local codes, such as the California Administrative Code - Title 25 (RV installation), might also be applicable. Installation codes and recommendations may change over time and vary between countries, states and municipalities. It is recommended that the standards in Table 2 be obtained for reference.

TABLE 2 REFERENCE CODES AND STANDARDS

<NA for control systems>	
NFPA 70 National Electric Code	National Fire Protection Association 470 Atlantic Avenue Boston, MA 02210
ANSI A119.2 (NFPA 1192) Standard on Recreational Vehicles	Recreational Vehicle Industry Association 14650 Lee Road Chantilly, VA 22021
California Administrative Code Title25, Chapter 3	State of California Documents Section P.O. Box 1015 North Highlands, CA 95660
CAN/CSA-Z240.6.2 Recreational Vehicles	Canadian Standards Association Housing and Construction Materials Section 1178 Rexdale Blvd Rexdale, Ontario, Canada M9W 1 R3

OEM Supplied Equipment

Required for Installation	Manufacturer & PN
Mating Connector Housing	Tyco/AMP 770583-1
Pins (Up 16 required)	Tyco/AMP 171637-1
2 or 3 5A DC Inline Fuses	Installers choice
Tools	
Pro-Crimper II W/Die 16-20	Tyco/AMP 189727-1
Contact Extraction Tool	Tyco/AMP 90760-1

Removing Magnetic Overlay

Insert fingernail beside the Stop/Start Switch and lift gently to remove magnetic overlay.

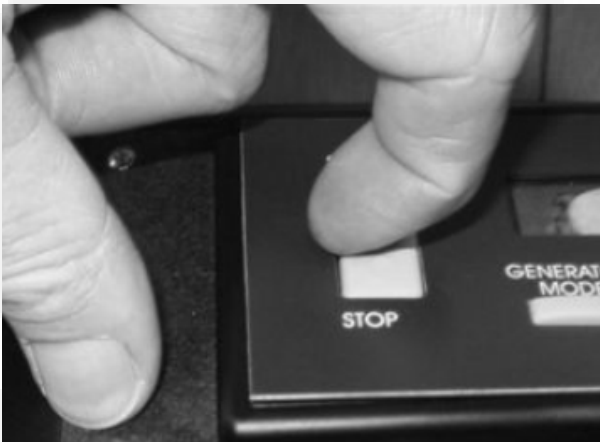

Installation Procedure

This procedure describes the physical installation of the unit.

Preparing to Mount the EC-20

- 1) Select a location:
 - a. Use the Mounting Template and the EC-20 itself to determine an appropriate location. It should be located in a visible location where it can be easily operated.
 - b. **CAUTION!** Check the backside (inside) of the chosen location to verify that nothing will interfere with drilling and cutting the opening for the remote, or with the fasteners, harness plug, or enclosure on the back of the EC-20.
 - c. Determine the feasibility of routing the control wires from the genset to the remote. Verify that the route of the control wires meets all applicable national and local codes.

Wires must be protected from all hot, sharp, and abrasive surfaces.

- 2) Prepare the chosen location for the genset controller.
 - a. Use scissors to cut out the template.
 - b. Tape the template to the mounting surface to be cut out, make sure that the template is "square or level" with the mounting surface.
 - c. Using a center punch and a hammer, punch a mark through the template for each fastener and at the perimeters of the cutout area.
 - d. Remove the template.
- 3) Drill the cutout starter holes at the four corners of the cutout area. Cut between them and remove the cutout.

NOTE: Because the location of the genset controller will vary by installation, the tools to be used and the cutout material (wood, metal, plastic, etc.) will differ. Therefore, the size of the cutout starter holes and the procedure for cutting between the starter holes must be determined by the installer.

- 4) Drill 1/8-inch diameter holes for the control panel fastening screws.
- 5) This completes the preparation of the mounting hole for the control panel. **Do not mount until wiring is complete.**

Wiring Guidelines

The wiring for the EC-20 may be single conductors of 16-20 AWG wire formed into a wiring harness. The wire must be rated for the environment, temperature, and applicable standards.

Separation from sources of Electro-magnetic Interference (EMI): All cabling should be installed in such a way as to comply with the **minimum** separation of 5 inches (127 mm) from AC power sources.

Tension: All wires should be free from tension at both ends, as well as over the length of each run.

UTP cable bends: UTP cable bends or radii should be no less than eight times the cable diameter.

!CAUTION! Incorrect connections can damage genset controls, remote devices, and interconnect wiring. Make sure that the leads between the connections are properly connected.

Wiring Installation

1. Use wire tags or labels to label each end of every wire. Use Figures 5 - 7 to determine the correct labels and connections.
2. At the controller end of the harness, insert the terminated and labeled wires into the correct positions in the connector body. Use Figures 5 - 7 to determine the correct positions.
3. At the genset end of the harness, insert the terminated and labeled wires into the correct positions in the connector body. Use Figures 5 - 7 to determine the correct positions.

Use tie wraps at not less than 20-inch intervals to keep the wire bundle neat. Use protective sheathing where necessary to protect the wires from sharp edges.

Genset Harness Installation

1. Route the harness from the genset to the control panel, making sure that the connectors on the harness match the corresponding connectors at each end. Wires must be protected from all hot, sharp, and abrasive surfaces.

!CAUTION! When DC wires are run with AC wires, electrical induction can occur and cause operational problems. Route the controller harness separately from AC load wires.

2. Seal any holes where the harness passes through bulkheads.

!WARNING! Exhaust gases are hazardous and may cause severe personal injury or death. Seal all holes to prevent the entrance of exhaust gasses into the vehicle interior.

Connections (Definitions)

This section describes each connection to the EC-20.

Genset Connections

WIRE #1 BATTERY GROUND (NEGATIVE): This wire supplies the ground or negative side of the circuit for the EC-20. It must be supplied from the genset.

WIRE #2 STOP OUTPUT: This wire supplies the stop signal to the genset. It is an active low or grounded output. It is controlled by the STOP/START switch.

Wire #3 START/PREHEAT: This wire supplies the start/preheat signal to the genset. It is controlled by the STOP/START switch and in the automatic mode by the EC-20.

Wire #4 NOT USED

Wire #5 Switched B+ From Genset: This wire is switched to the battery positive voltage when the genset is running. It is used to provide a signal for the genset hour meter and to indicate the genset is running.

Wire #6 Genset Status Light: This wire supplies a diagnostic output from the genset that flashes the red light in the START/STOP switch to indicate a genset fault. The status light output is decoded by the EC-20 to display a text fault message.

Power and Voltage Connections

WIRE #7 8-35VDC Power +: This wire is the positive power supply to the EC-20. It may be supplied from the distribution side of the DC disconnect if it is desirable to have all DC loads off when the disconnect is off. It must be protected by a 5A inline fuse located as close to the battery or source as possible. **Do not install the fuse until the installation is complete. Install fuse just prior to testing the installation.**

WIRE #8 House Battery Sense 12-24VDC: This wire supplies the positive sense voltage to the unit which is displayed as the house battery voltage and is used to determine the house battery state-of-charge indicator. It must be connected directly to the battery. It must be protected by a 5A inline fuse located as close to the battery as possible. **Do not install the fuse until the installation is complete. Install fuse just prior to testing the installation.**

WIRE #9 Engine Battery Sense 12-24VDC: This wire supplies the positive sense voltage for the engine starting battery. This is an optional feature. The engine battery voltage will only be displayed if it is connected. It must be connected directly to the battery. It must be protected by a 5A inline fuse located as close to the battery as possible. **Do not install the fuse until the installation is complete. Install fuse just prior to testing the installation.**

WIRES #10 – #16 NOT USED

Final Connections and Testing

This section describes the final connections and the test procedure to verify that the unit has been installed correctly and is operating properly.

1. Plug the genset end of the connector into the genset.
2. Pass the controller end of the harness through the cutout for the controller.
3. Plug the controller end of the harness into the controller.
4. Insert the controller in the cutout hole and secure it with the screws supplied with the controller. **DO NOT OVER-TIGHTEN MOUNTING SCREWS, IT MAY DAMAGE OR DISTORT THE ENCLOSURE.**
5. Install the magnetic overlay.

Test Procedure

The following test procedure describes a systematic method of testing both the installation and operation of the EC-20. It is highly recommended that the installer follow these steps:

1. Reconnect the genset negative (-) battery cable.
2. Insert the fuse in the fuse holders for: Wire #7 8-35VDC Power, Wire # 8 House Battery Sense, and Wire #9 Engine Battery Sense.
3. Refer to Setting Up section of this manual to select the genset type.
4. **Setting the Hour-Meter: If the EC-20 is installed on a new genset this step may be skipped.** See Setting Up section of this manual.
5. Start and stop the genset using the Stop/Start switch located at the genset. This confirms the genset operation.
6. Start the genset at the EC-20 and check the following:
 - a. The indicator light in the controller Start/Stop switch flashes while the genset engine is cranking. This verifies that the diagnostic wiring is correct. (Only for units with diagnostics.)
 - b. Genset starts and continues to run.
 - c. The indicator light in the Start/Stop switch remains illuminated when the genset is running.
 - d. Use the Up/Down Switch to the right of the display to scroll to the Hour Meter display and confirm that it is operating.
 - e. Use the Up/Down Switch to the right of the display to scroll to the Volt

Meter display and confirm that it is operating.

7. Stop the genset at the controller and check the following:
 - a. The genset stops
 - b. The indicator light in the Start/Stop switch turns off.
 - c. The Hour Meter stops.

Troubleshooting

If controller functions do not operate properly, proceed as follows:

1. Does the genset operate correctly from the genset controls? If it does not, the problem is in the genset, not the EC-20 controller. See the genset Operator, Installation, and Service Manuals. .
2. If the genset operates correctly from the genset controls, Confirm that the correct connection diagram (Figures 5 - 7) was used, then check EC 30 wiring connections.
3. Confirm that the correct voltages are present on each terminal.
4. Check all terminal connections on both ends of the wiring harness. Are harness connectors properly joined?
5. Repeat the TEST SYSTEM procedure as described in this Operation and Installation Manual.

How to Obtain Customer Service

If you require service, parts, or product literature, contact the nearest Onan dealer or distributor. To locate the nearest authorized dealer or distributor, in the United States or Canada call 1-800-888-ONAN for name and telephone number (This automated service utilizes touch-tone phones only). By calling this number, you can also request a directory of authorized RV servicing dealers:

RV Sales and Service Directory F-919.

To get service, contact the authorized dealer or distributor nearest you. Explain the problem and make an appointment. If you have difficulty in arranging for service or resolving a problem, please contact the dealer coordinator or service manager at the nearest Onan dealer for assistance.

Before calling for service, have the following information available:

1. The complete model number and serial number.
2. Software version number, as shown in the SYSTEM INFO displays.
3. The date of purchase.
4. The nature of the problem.

To enjoy the benefits the product offers requires an understanding of this manual. If you have ideas for its improvement we happily accept editorial comments.

!WARNING! Improper service or replacement of parts can result in severe personal injury, death, and/or equipment damage. Service personnel must be trained and experienced to perform electrical and/or mechanical service.

Warranty Policy

The ONAN limited warranty covers your Energy Command 20/30 Control for the first three (3) years you own your EC 20/30 if purchased at the same time as an Onan generator. Energy Command 20/30 Controllers sold separately are covered for 90 days.

For complete Onan Limited Warranty details contact your Onan RV Service and Parts dealer or call:
1-800-888-ONAN (1-800-888-6626).

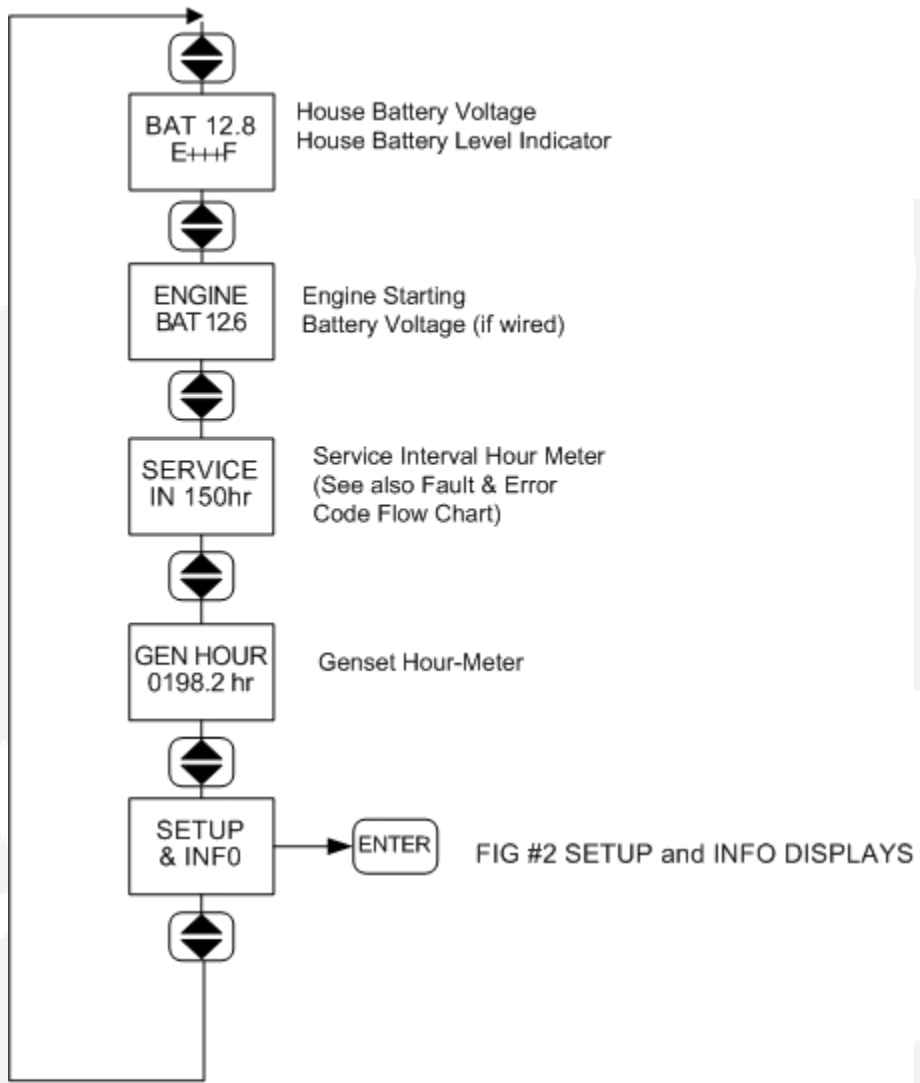

FIGURE #1 MAIN DISPLAYS MAP

Setup and Information Displays

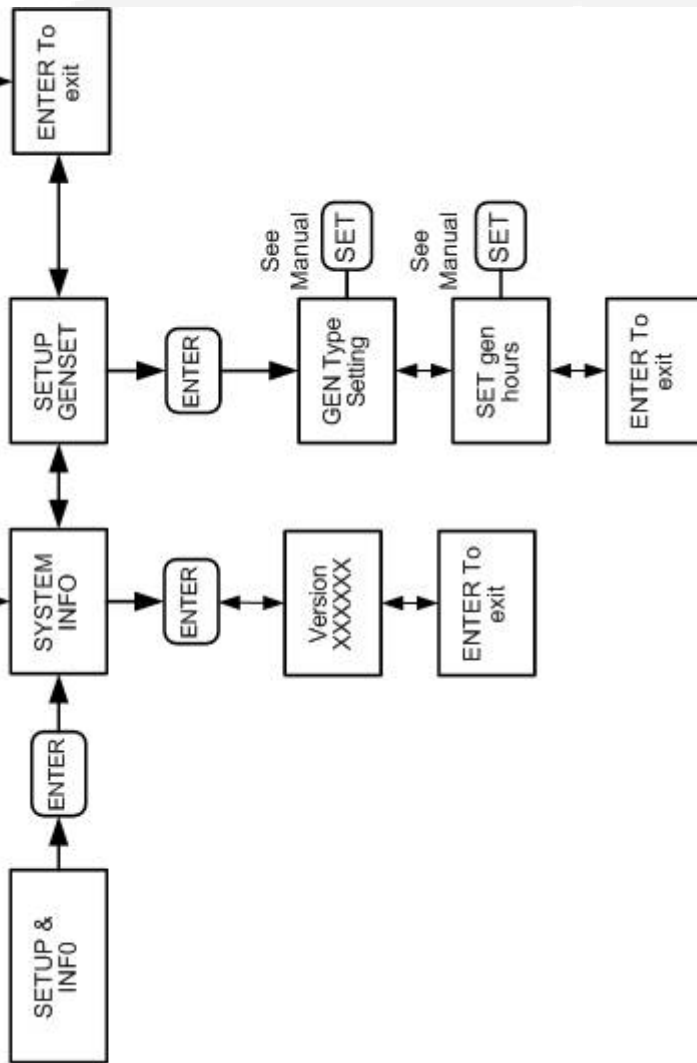
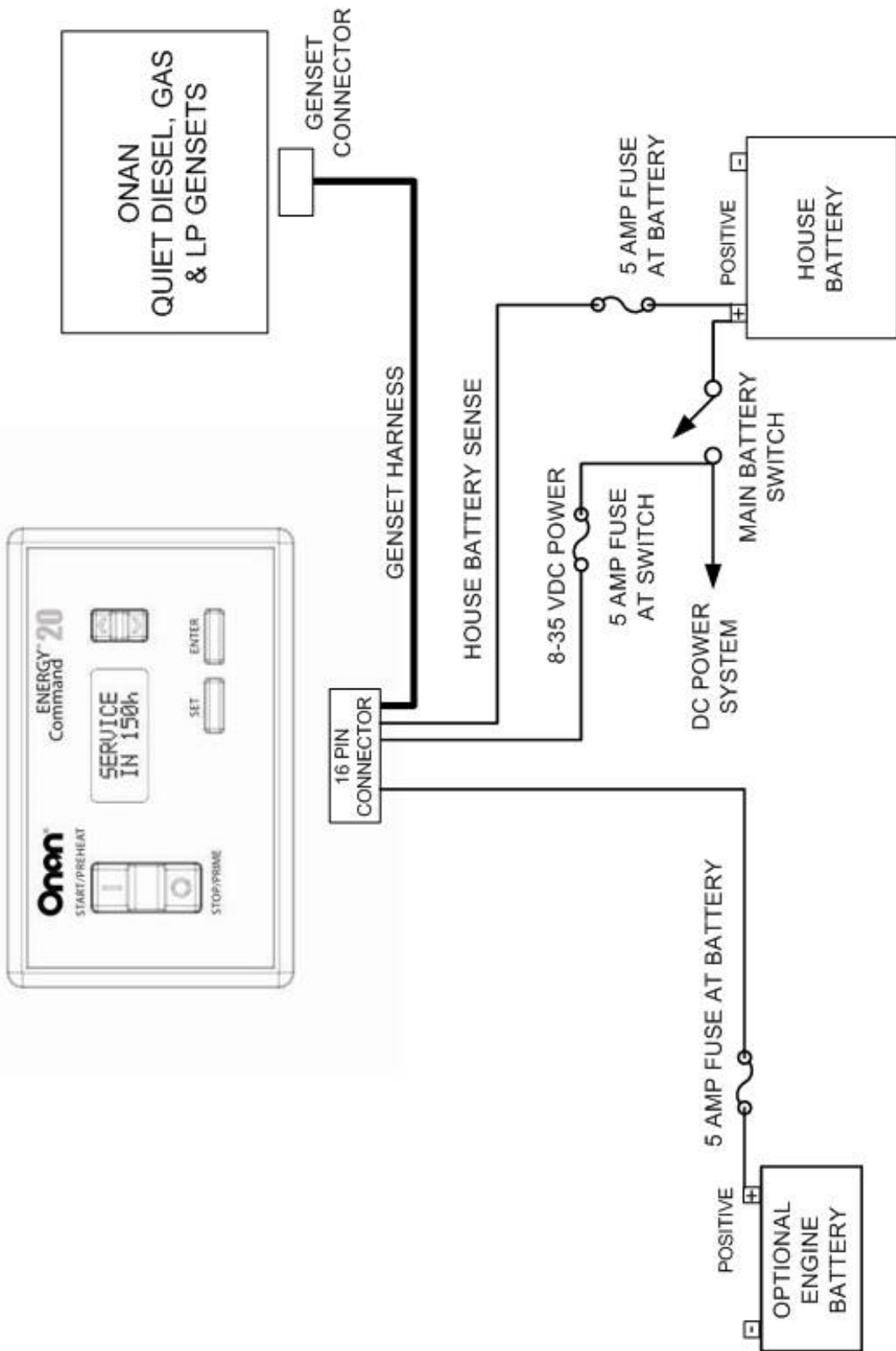

FIGURE #2 SETUP AND INFO DISPLAYS

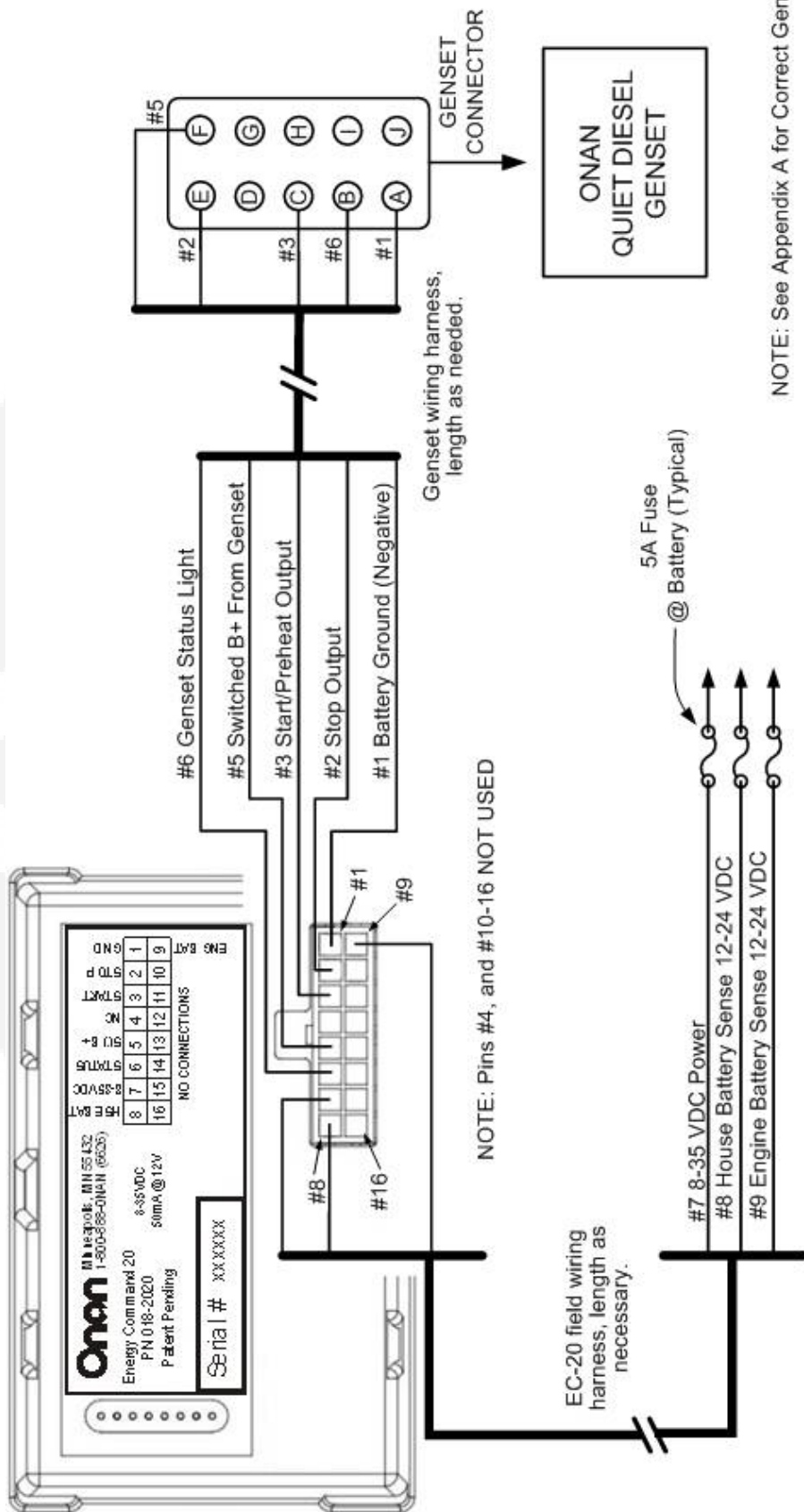

FIGURE #3 INTENTIONALLY BLANK



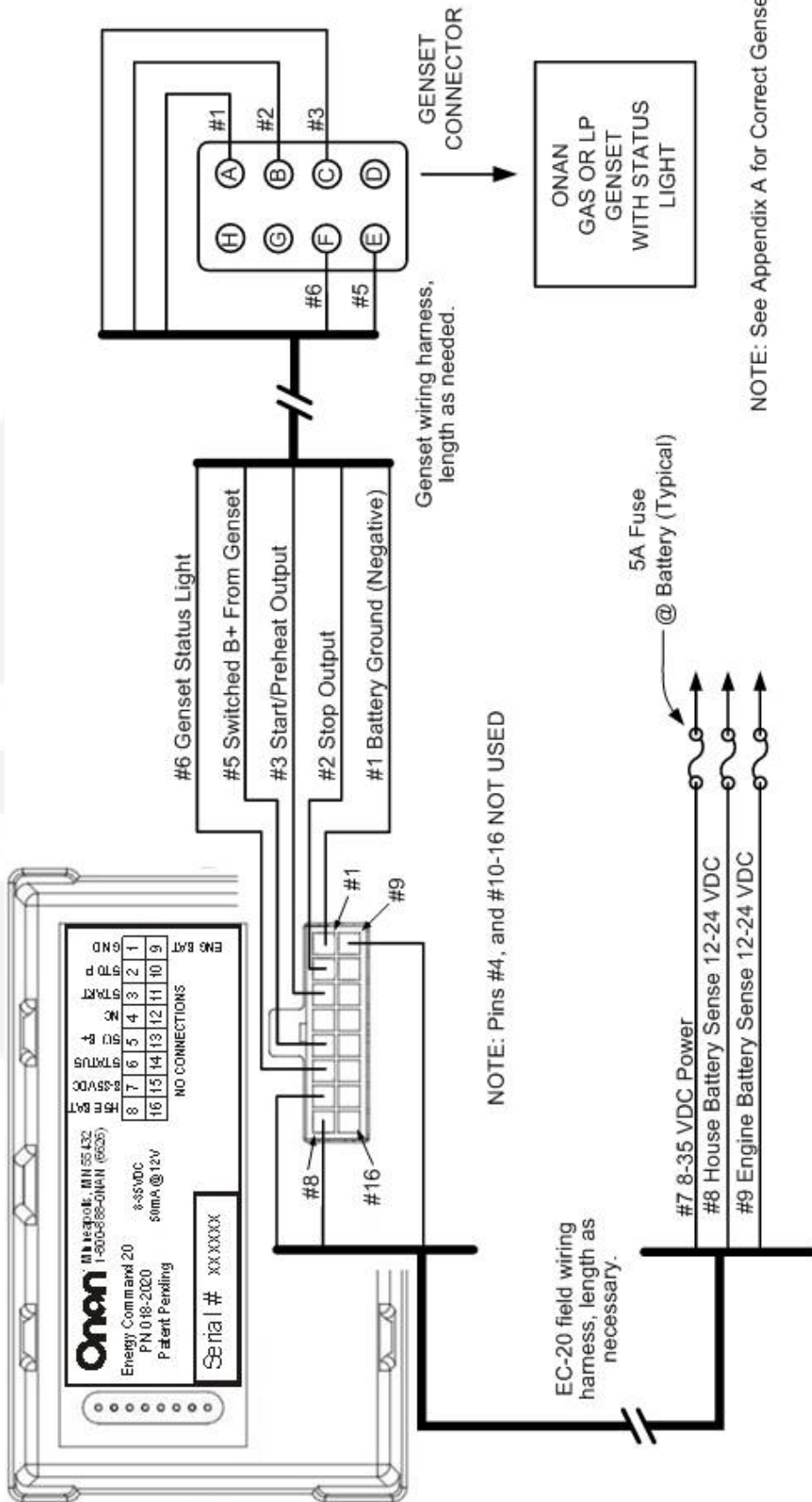

**FIGURE #4
ENERGY COMMAND 20
SYSTEM DIAGRAM**



NOTE: See Appendix A for Correct Gensets

FIGURE #5
ENERGY COMMAND 20
CONNECTIONS FOR
ONAN QUIET DIESEL



NOTE: See Appendix A for Correct Gensets

FIGURE #6
ENERGY COMMAND 20
CONNECTIONS FOR
GAS/LP WITH DIAGNOSTICS

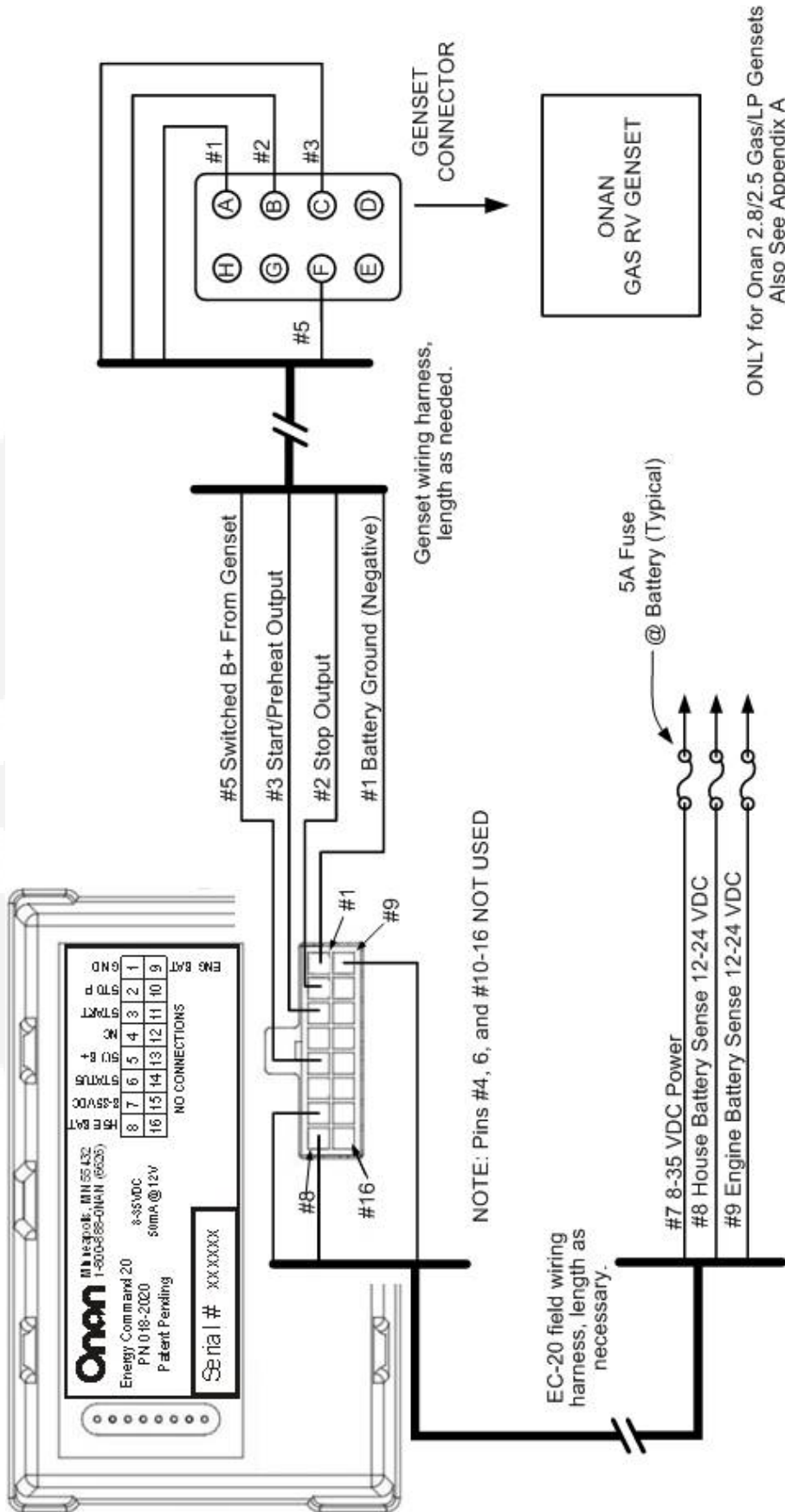

ONLY for Onan 2.8/2.5 Gas/LP Gensets
Also See Appendix A

FIGURE #7
ENERGY COMMAND 20
CONNECTIONS FOR
GAS RV GENSETS

Appendix A Onan Gensets for Use With the EC-20/30

QUIET DIESELS

MODEL	KW	PRODUCT	EC-20/30 GEN TYPE	Service IN Hours	Connection Figure	Onan IN Cable No.
HDCAx	10/12	Quiet Diesel	QD 10/12	250	5	044-00076
HDKCx	10/12	Quiet Diesel	QD 10/12	250	5	044-00076
HDKAx	6/8	Quiet Diesel	QD 7.5/8	150	5	044-00076
HDKBx	5.5	Quiet Diesel	QD 5.5	150	5	044-00076
HDKBx	5.0	Quiet Diesel	QD 5.5	150	5	044-00076

GASOLINE/LIQUID PETROLEUM (LP) (with Status Light)

MODEL	KW	PRODUCT	EC-20/30 GEN TYPE	Service IN Hours	Connection Figure	Onan IN Cable No.
HGJAx	7.0	Marquis Platinum	GAS/LP	150	6	044-00075
HGJAx	5.5	Marquis Gold	GAS/LP	150	6	044-00075
KY	4.0/3.6	MicroQuiet	GAS/LP	150	6	044-00075
KYD	4.0/3.6	CampPower	GAS/LP	150	6	044-00075

GASOLINE/LIQUID PETROLEUM (LP) (without Status Light)

Note 1: This genset model *does not* support diagnostic fault codes.

MODEL	KW	PRODUCT	EC-20/30 GEN TYPE	Service IN Hours	Connection Figure	Onan IN Cable No.
KVD	2.8/2.5	CampPower (Note 1)	GAS/LP	150	7	044-00074
KV	2.8/2.5	MicroLite (Note 1)	GAS/LP	150	7	044-00074

- 25 foot cables available through Onan IN. Cables have mating connectors for EC20/30 and genset, flying leads for other connections.
- Also available is an 18" pigtail, part number 044-00077, without the genset connector that mates to the EC20/30.

The mounting footprint for the control is shown below. Select an appropriate mounting location, make sure there is enough room to install the control panel, and mark the locations for the cutout area and the mounting holes, as indicated in the illustration. Use a center punch to mark the perimeter of the cutout area.

Depending on the tool to be used (Roto-zip tool recommended, reciprocating saw, or key hole saw), determine where to drill the corner starting holes. The edge of the bit should just touch the

edge of the cutout area. Also lightly punch or mark the two mounting holes.

Use the perimeter punch marks to draw an outline on the cutout area on the mounting surface. Drill the corner starting holes and use the selected tool to remove the cutout area. File the corners and as needed to fit. Align the EGR-1 and check that the mounting hole punch marks line up. Adjust mounting hole marks as needed and drill mounting holes appropriately for the screws being used to mount the unit.

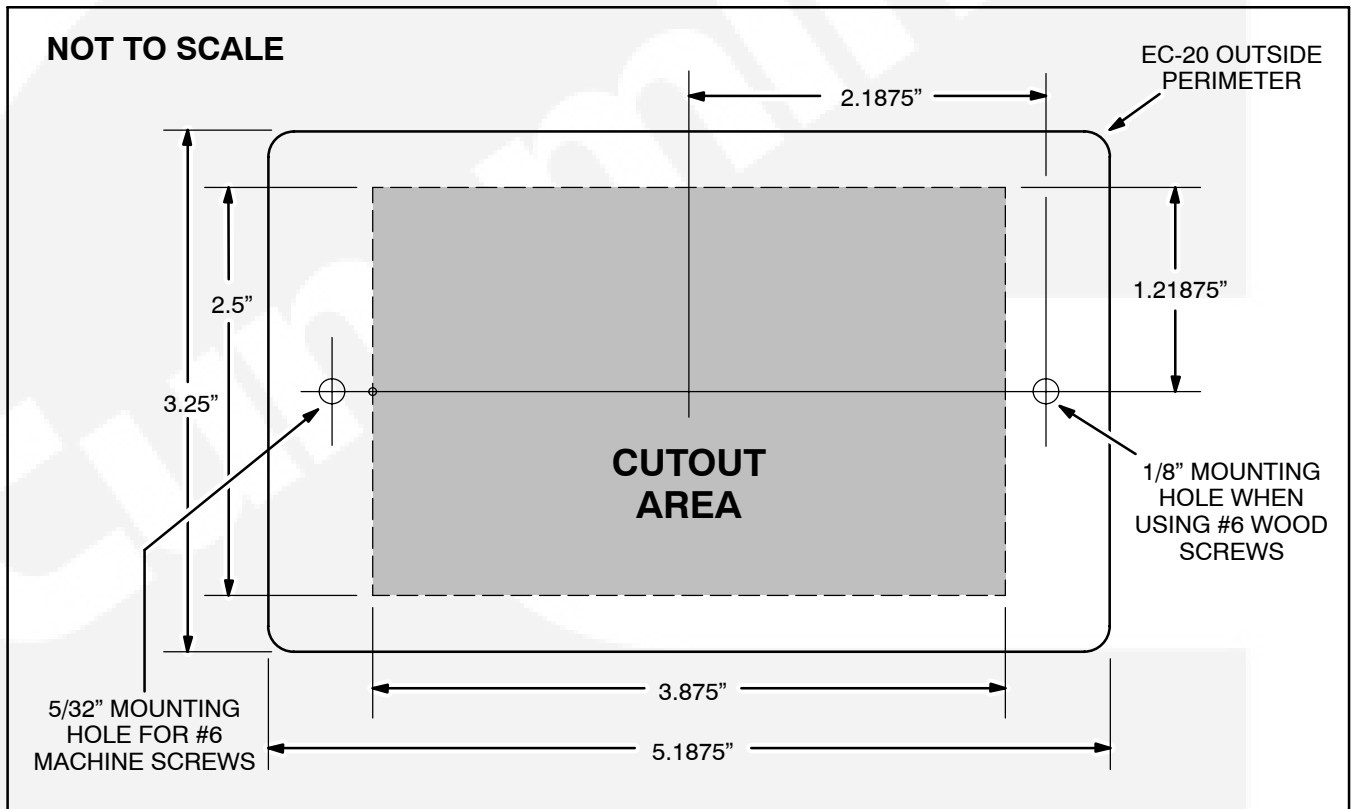

Mounting Footprint



Cummins

Cummins **Onan**

Cummins Power Generation

1400 73rd Ave. NE
Minneapolis, MN 55432 USA

Phone 1 763 574 5000

Toll-free 1 800 888 6626

Fax 1 763 574 5298

Email www.cumminsonan.com/contact

www.cumminsonan.com

Cummins®, Onan®, the "C" logo, and "Performance you rely on." are trademarks of Cummins Inc.

©2007 Cummins Power Generation, Inc. All rights reserved.

